

UNDERMOUNT CUT OUT

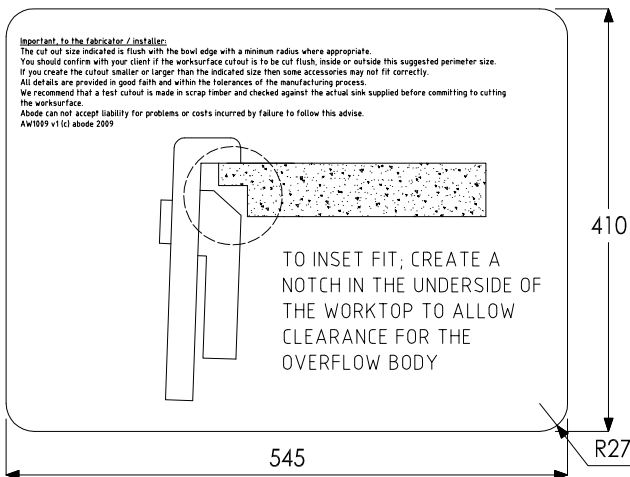

INSET CUT OUT

