

Important Technical Data

Minimum operating pressure 0.4 bar
Maximum operating pressure 5.5 bar*

Maximum hot water temperature 70°C*
Recommended hot water temperature 46°C

Note: If these temperatures or pressures are exceeded, even for short periods, damage can result. In these instances a thermostatic mixing or pressure reducing valve should be installed.

Hot and cold supply pressures should be as closely balanced as possible for best results. Supply pipes should maintain the maximum diameter until immediately before the fitting. The differential between the hot and cold water supply temperatures should be sufficient to allow correct mixing function.

All Abode taps are either WRAS approved or manufactured in accordance with recognised European standards. Please ensure that your Abode product is fitted in accordance with Local Water Byelaws. Where hot and cold water mix within any product, then suitable non return valves should be installed to the hot and cold supplies to prevent backflow.

Whilst assembling this product take care not to accidentally loosen any screwed assemblies. PTFE tape can be used to ensure watertight joints on threaded connections, do not over tighten connections or allow pipes to be twisted or folded.

The installation should be periodically checked for damage, if the property is left unattended for a prolonged period we recommend isolating water supplies.

Abode is a registered trademark of Abode Home Products Limited. All errors and omissions excepted.

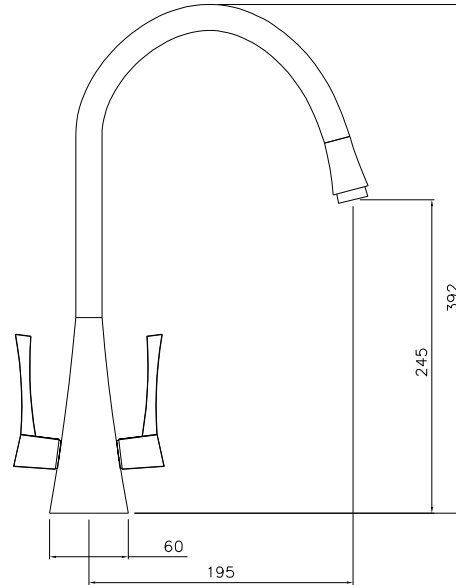

Manufacturers Product Reference

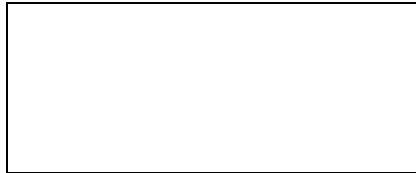

©Abode
02/2009

abode

Abode Home Products Limited, Unit L, Zenith Park, Whaley Road, Barnsley, S75 1HT.
Tel: 01226 283434 Fax: 01226 282434 www.abode.eu

All errors and omissions excepted.

Decadence Monobloc



5 Year warranty Terms and Conditions

In the unlikely event that you should experience any defect in the materials or workmanship of your new Abode mixer within FIVE years of purchase, the purchaser's sole remedy shall be the replacement (at the manufacturer's discretion) of all or any part of the product that is defective. All working parts and valves are guaranteed for a period of TWO years from purchase. Decorative surface finishes and O-rings are guaranteed for ONE year from the date of purchase provided that our advice concerning care has been observed and no scouring agents have been used.

This is provided that the mixer has been used for normal domestic purposes in the UK and that the care, installation and maintenance instructions have been observed. The warranty extends to the original purchaser only. You should retain a copy of your dated invoice as proof of purchase to validate any claims under this guarantee.

Marks, scuffs and scratches caused by improper installation or accidental damage are not covered by this guarantee. Neither are shade variations or any

Care Instructions for your Kitchen Sink Mixer

To maintain the appearance of this tap, ensure that it is regularly cleaned only using a clean, soft damp cloth. A solution of warm water and a mild liquid detergent may be used where necessary, and then the fitting rinsed thoroughly and wiped dry. Any other cleaning action will invalidate your warranty.

If the mixertap has a diffuser it should be unscrewed and cleaned periodically in warm water.

Abrasive cleaners, scouring cleaners and acidic cleaners **must not be used** under any circumstances. Avoid contact with all solvents (including chlorinated solvents, ketones or acetones as these may result in surface deterioration or etching). Also avoid contact with any harsh household chemicals such as oven cleaners, drain cleaners, rust removers, paint strippers and toilet bowl cleaners, bar keepers friend or Brasso.

Please leave these instructions for your customer.

damage or defect caused by incorrect installation or abuse of the fitting.

As we are continuously improving and developing our range of products, finishes & colours, in the event of a valid claim, we may not be able to provide an identical replacement for the defective product throughout the guarantee period. Where an identical product is no longer available, we will supply the nearest equivalent from our then current product range. In assessing your claim, we must be given the opportunity to inspect the product as installed prior to removal. Any product returns must be packaged as received and complete.

No other warranties, express or implied, are made, including merchantability or fitness for a particular purpose. Under no circumstances shall the manufacturer be liable for any loss or damage arising from the purchase, use or inability to use this product, or for any special, indirect, incidental or consequential damages. No liability is accepted for consequential damage to other household fixtures, fittings or furnishings arising from this claim, even if attached to the product. No installer, dealer, agent or employee of Abode Home Products Limited has the authority to modify the obligations or limitations of this warranty.

Parts and Contents

Key	Description	Qty
A	Mixertap body	1
B	Upper seal	1
C	Fixing stud	1
D	White triangular stabiliser (for stainless steel sinks only)	1
E	Lower Gasket	1
F	Metal horseshoe	1
G	Fixing nut	1
H	Hot water tail pipe	1
I	Cold water tail pipe	1
J	Non-return valve (internal to H)	1
K	Non-return valve (internal to I)	1

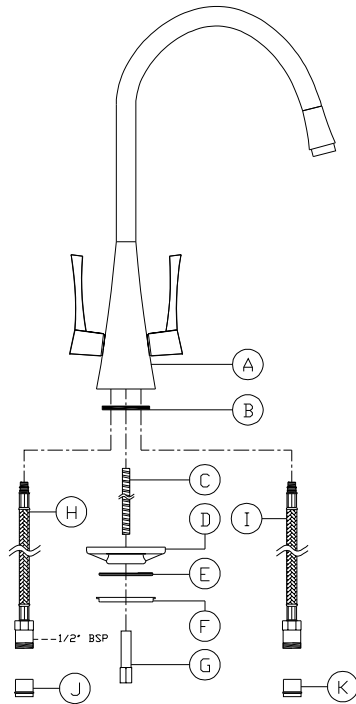

Installation Instructions:

Preparation

All parts should be removed from their packaging and inspected for any transport damage and completeness prior to installation; you should read these instructions throughout before commencing installation. We do not accept responsibility for problems that may occur through improper installation. Always ensure you have sufficient hot and cold water pressure available to allow correct function before specifying or installing this product. You should ensure that the product will both fit into the depth of the mounting surface available and reach the required outlet position before installation.

Before installing the new mixer it is essential that you thoroughly **flush through the supply pipes** in order to remove any remaining solder, swarf or impurities from your system. Failure to carry out this simple procedure could cause problems or damage to the workings of the mixertap.

We strongly recommend installing particle filters and isolation valves to both the hot and cold feed pipes in an accessible position. This will help to prevent premature failure of the valves and ease any future maintenance.

Shut off your water heating system and ensure that your mains stopcock is closed. Ensure both the hot and cold water supplies are isolated before commencing installation.

This mixertap requires a 35mm \varnothing tap hole, if replacing an existing tap, remove the tap & clean the end of the feed pipes using wire wool the tap hole area should be free from dirt and sealant. Loosely position the tap and tail pipes to check if any alteration to the existing pipework is required, if this is the case do this now.

Installation

1. Screw the fixing stud (C) into the base of the tap (A).
2. Screw the tail pipes (H&I) into the base of the tap (A), note the hot tail pipe (H) should typically be connected to the left hand side of the tap when viewed from the front.
3. Pass the upper seal (B) over the fixing stud (C) and tail pipes (H&I), locate the upper seal (B) centrally on the base of the mixertap (A).
4. Place the mixertap (A) onto the sink or worktop and pass the tail pipes (H&I) and fixing stud (C) through the taphole. With the tap in place check that the tails (H&I) meet the hot and cold water feeds. If further adjustment to the plumbing is required do this now. Note: do not twist, stretch or kink the tail pipes.
5. If fitting the tap to a stainless steel sink the white triangular stabiliser (D) can be placed where shown to help to stabilise the weight of the tap. Otherwise stabiliser (D) can be ignored.
6. Pass the lower gasket (E) and then metal horseshoe (F) over fixing stud (C) and around tail pipes (H&I).
7. Fasten the fixing nut (G) securely onto the fixing stud (C) fixing the tap into its correct location.
8. Connect the hot and cold water tail pipes (H&I) to the water supply pipes using 15mm compression fittings or similar.

After installation

Once you have visually checked the installation of the new tap and all connections, ensure that all other fittings are closed except the new tap which should be left open.

Turn on your water heating system and ensure that your mains stopcock is open. Reconnect both the hot and cold water supplies to this fitting.

Check the function of flow and function of hot, cold and mixed water.

Turn off the tap and check carefully for any leaks around all connections on the fitting and adjoining plumbing.

If possible return to the installation after a longer period to double check for slower leaks.

If pressure testing equipment is available check the installation to the maximum recommended pressure.

Clean the tap to remove any marks created during installation as instructed then place a bag over the product to protect the tap until it is ready for use.

